

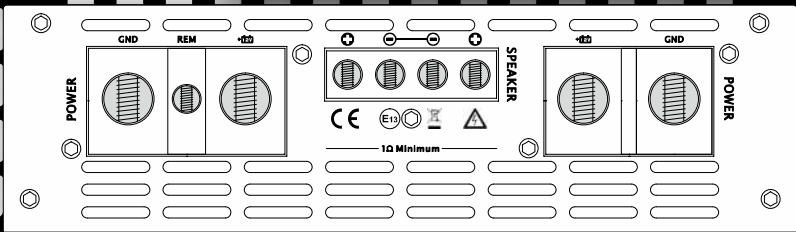

...is all you need

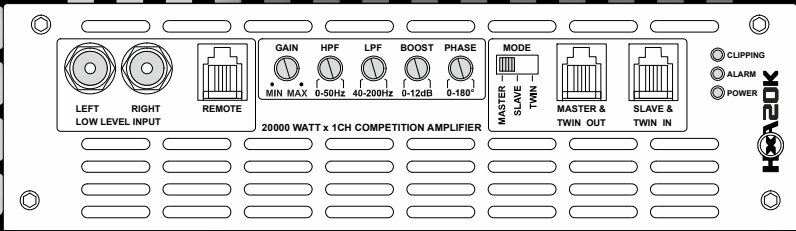

HXA MONO COMPETITION AMPLIFIER

CONGRATULATIONS !

You now own an EXCURSION HXA True Mono Competition Amplifier, the product of an uncompromising design and german engineering philosophy. A product made from Car Audio fanatics who truly believe in the relentless pursuit of perfection.

EXCURSION amplifiers are the result of several decades of product improvements, competition, innovation and highest quality parts and control standards in industry. When properly installed these amplifiers will provide you with many years of listening pleasure and are the perfect balance between high fidelity, extreme performance and long-lasting reliability.

Should your amplifier ever need a service, Please record your information on the following lines to refer to in the event that you may need it later.

Dealer's Name _____

Date of Purchase _____

Installation Shop _____

Installation Date _____

At EXCURSION Intl. we are confident you will have many years of outstanding enjoyment from your high performance investment. For maximum performance we recommend that you have your new EXCURSION HXA Amplifier installed by an exclusive Authorized EXCURSION Dealer

To learn more about EXCURSION, please visit us on the World Wide Web at

<http://www.excursion.us>

CAUTION !

Continuous exposure to sound pressure levels in excess of 100dB can cause permanent hearing loss. EXCURSION Products are capable of producing sound pressure levels well over 170dB. Please observe all local sound ordinances while listening to your EXCURSION System. EXCURSION Intl. accepts no liability for hearing loss, bodily injury, or property damage due to the result of use or misuse of this product.

HXA MONO SPECIFICATIONS



Model	HXA1K	HXA2K	HXA3K	HXA4K	HXA5K	HXA8K	HXA12K	HXA20K	
Description	1 Channel								
0.5Ohm Load @ 14.4V	NA	NA	NA	NA	3500W*	NA	NA	14000W*	
1Ohm Load @ 14.4V	NA	1200W	1800W	2400W	3000W	7000W	10000W	10000W	
2Ohm Load @ 14.4V	600W	800W	1200W	1600W	2000W	5000W	7000W	6000W	
4Ohm Load @ 14.4V	400W	400W	600W	800W	1000W	3000W	4000W	3000W	
4Ohm Load @ 14.4V	NA								
4Ohm BRIDGE 2 AMPS	1200W	1600W	2400W	3200W	4000W	NA	NA	12000W	
2Ohm BRIDGE 2 AMPS	NA	2400W	3600W	4800W	6000W	NA	NA	20000W	
1Ohm BRIDGE 2 AMPS	NA	NA	NA	NA	7000W*	NA	NA	28000W*	
FEATURES									
Amplification	Mono Digital					Mono FRD		Mono Digital	
Input Sensitivity	0.2 ~ 5.0 V Low Level (PRE)					0.2 ~ 7.0 V Low Level			
	0.5 ~ 15.0 V High Level (SPK)					0.5 ~ 12.0 V High Level			
Auto Turn ON/OFF	DC (Headunit) or AUDIO (amplified music impuls)						NA		
Frequency Response	5 ~ 300Hz					5 ~ 20KHz		5 ~ 300Hz	
Low Pass Filter	0 ~ 200Hz					50 ~ 15KHz		40 ~ 200Hz	
HPF or BPF Subsonic	0 ~ 50Hz					0 ~ 500Hz		0 ~ 50Hz	
Bass Boost	0 ~ 12dB @ 45Hz								
Phase Shift	NA								
TWIN Settings	NA								
BRIDGE AMPS	YES				NA				
Temp Management	NA				2x Fans		1x Fan		
Minimum Load	20hm	10hm			0.50hm*	10hm		0.50hm*	
S/N Ratio	> 100%					> 80%		> 95%	
THD @ 40hm Load	< 0.2%					< 0.5%		< 0.1%	
Efficiency @ 40hm	> 80%					> 90%			
Low Voltage Protection	YES < 8Volt								
Overheat Protection	Protect @ 80° / 176F								
Short Circuit Protection	YES - Test PASS								
Components & PCB	military standard / SMD parts / double side FR-4 PCB								
ext. Fuse Requirement	60A	100A	150A	200A	250A	500A	800A	1000A	
Power Terminal +/-	Screw	4GA			0GA		Dual 0GA		
Speaker Terminals	Screw	8GA					8GA		
DIMENSION									
Height	54 mm					70 mm			
Width	140 mm					240 mm			
Length (Heatsink) mm	200	280	355	405	530	440	540	730	

* Competition and Experts use only. Not recommended. Damages not covered through manufacture warranty.

We recommend all amplifiers driven on their minimum Impedance at least Dual or even Tripple Power Input Adapters. Wired with solid and fine stranding OFC (Oxygen Free Copper) Cables. These shortest distance to the closest next 12V capacity. Cable diameter not less than the INPUT Terminal Diameter.

Please mind experiments with CCA (Coper Covered Aluminium) Cable at this high performance levels. At least use not CCA between the Amplifier and your closest 12V Capacity (Capicator or AGM Battery).

All MONO Amplifier already require for proper performance an extra Capacity with short distance to the Amplifier. This to keep up & stable the voltages. This to mind clipping and damages from your electronics and speakers. Solid Car Audio Capicators are usefull up to 2000W. Upper 1000W an extra Car Audio AGM Batterie is seriously required from praxis experience . A mix with Capicators is welcome but those act not like a real energy storage and can not get compared with AGM Batteries at higher consumption demands.

All Amplifiers need external fusing to avoid electronic damages. Asure a max. distance 30cm to the amp. Choose Fuse values according above recommendations. Note for protection of (loading) cable, car & life, there is a Fuse required after the Main batterie and another short before the Rear Batterie. Both with max. distance 30cm to each Batterie. Choose Fuse values according Diameter recommendations of your cable.

FRONT PANEL LAYOUT

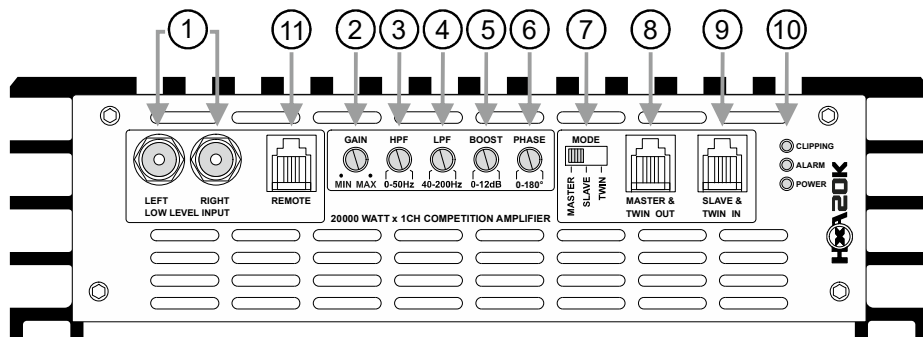

1. RCA Audio Input

These RCA Input jacks connect with your source unit RCA Low Level Outputs. High quality twisted RCA audio cables are recommended to mind possibility of disturbance the audio signal.

2. GAIN Control

The Gain controle will match the amplifiers sensitivity to the provided source unit signal voltage.

3. HIGH PASS FILTER Control

This knob controls the frequency x-over point from where Low Frequency can be cut out.

4. LOW PASS FILTER Control

This knob controls the frequency x-over point from where High Frequency can be cut out.

5. BASS BOOST

This knob adjust the 45Hz signal boost level from 0 up to 12dB. Preferable for small size cars.

6. PHASE Controle

This knob adjust the signal phase from 0 up to 180°. This to mind wave eliminations at the overlay frequency range with your Frontspeaker in your car.

7. MODE Switch

This Switch select the Status of this Amplifer. This set the Amplifier to the MASTER or in 2nd Ranking as the SLAVE or to the one of more possible TWIN Amplifiers.

8+9. MASTER & SLAVE and TWIN - INPUT and OUTPUT

For LINK of 2x HXA 20K Amplifier the MASTER will have control over all functional settings of the SLAVE Amplifier using the cable provided. The BRIDGED Couple act as one Amplifier.

For TWIN of 2x or more HXA 20K Amplifiers the MASTER will have control over all functional settings of the one or more TWIN Amplifiers, using the cable provided.

10. POWER, ALARM & CLIPPING Indicator

When device is powered ON, the POWER LED will turn on green. When device enters into protection, the ALARM LED will turn on red. When signal is clipped, the CLIP LED turn yellow.

11. REMOTE - Bass Level Control

The Volume of your HXA Mono Amplifier can get adjusted via remote controle from driver seat.

REAR PANEL LAYOUT

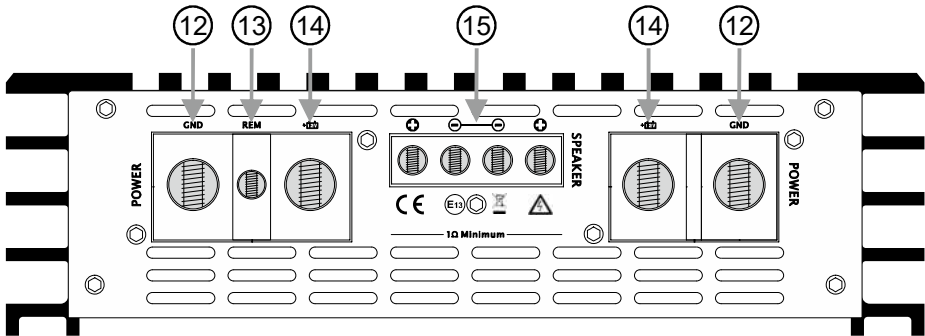

12. GND (Ground Connection)

This terminal is to connect directly to the frame of vehicle. Use shortest distance possible and equal or larger AWG OFC Cable size than +12Volt Battery Cable. Asure frame has been cleaned to bar metal.

13. REM Terminal

This Remote terminal is to connect with headunit 12V remote output to turn ON/OFF the amplifier according operating of headunit. If there are more amplifier connected to this terminal it might be necessary, depending on REM performance of headunit, to install an additional relay.

14. (+)12 Volt Battery Terminal

Connect this terminal with proper 0 GA size OFC Power Cable through a Fuse to the positive terminal of the car battery or the positive terminal of an isolated external car audio battery.
WARNING: Always protect the Power Cable via Fuse less than 12inch (30cm) from battery terminal.
WARNING: HXA Amplifiers need external Fuse not less than 12inch (30cm) from Power terminal. Please follow the maximum Fuse recommendation from Excursion HXA MONO Specifications.

15. Speaker Terminals

Connect your speaker to these terminals with proper polarity. Minimum speaker cable 10GA, 8GA OFC strongly recommend. Minimum impedance 10hm, linked a Couple HXA 20K 20hm. Never connect the speaker cables with chassis ground, effect short circuit and damage amplifier.

⚠ CAUTION

Before attempting to make any connections to power supply, input and output connectors, make sure the amplifier is in OFF state. Check polarity of cables carefully as using reversed polarity will cause damage to amplifier. And to prevent power loss and overheating of wiring, always use the recommended wire gauges.

⚠ CAUTION

Installation of the amplifier should be done in the following steps:

1. Ensure that the ground is appropriate, then connect it to the amplifier.
2. Next step is to connect the +12V wire. Ensure all power terminals are used.
This cable has to be fused for safety precautions.
3. The final step is connecting the switched remote.

MASTER / SLAVE CONNECTION

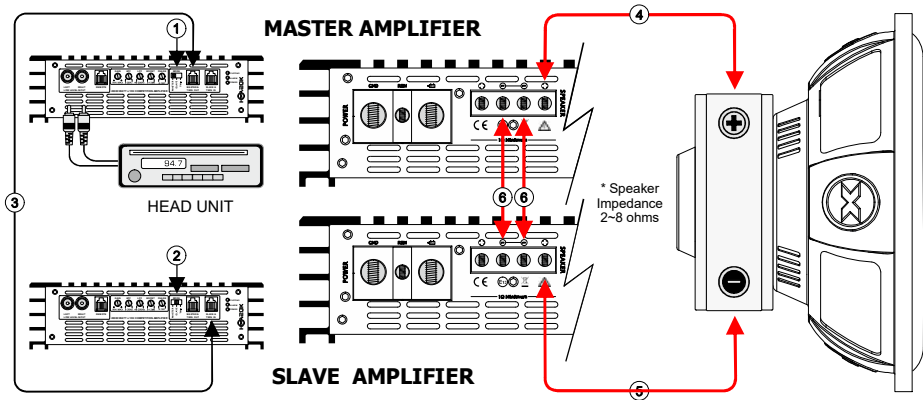

MASTER & SLAVE connection allows LINK/BRIDGE of 2x HXA20K Amplifiers to work as one bigger Amplifier.

1. Connect 1st amplifier to head unit and slide the MASTER/SLAVE/TWIN switch to MASTER position. (MASTER)
2. Slide at 2nd amplifier the MASTER/SLAVE/TWIN switch to SLAVE position. (SLAVE)
3. Connect the MASTER and SLAVE Amp using the LINK cable provided in package as shown in the diagram.
4. Connect speaker cable (+) on MASTER Amplifier to Subwoofer (+)
5. Connect speaker cable (+) on SLAVE Amplifier to Subwoofer (-)
6. Connect speaker cable (-) on MASTER to Terminal (-) on SLAVE Amp using 2x 8GA OFC Power Cable.

TWIN CONNECTION

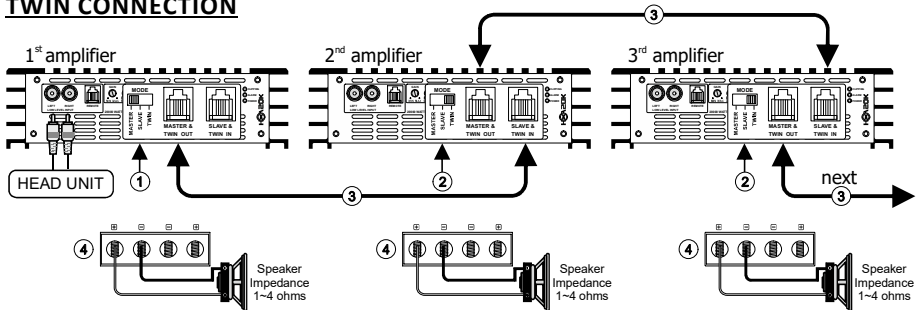

TWIN connection allows any number of HXA20K have same Signal, GAIN and Setup Settings via MASTER.

1. Connect 1st amplifier to head unit and slide the MASTER/SLAVE/TWIN switch to MASTER position. (MASTER)
2. Slide at all further HXA20K amplifiers at the MASTER/SLAVE/TWIN switch to TWIN position. (TWIN)
3. Connect the MASTER and TWIN Amps using the LINK cable provided in package as shown in the diagram.
4. Connect speaker cable each HXA20K Amplifier in the standard way of a single Amplifier connection.



The minimum impedance of each single HXA20K is 1Ω.
 In MASTER & SLAVE configuration the minimum impedance is 2Ω.
 In MASTER & TWIN mode, the minimum impedance each HXA20K is 1Ω.

TROUBLESHOOTING

Assure that the Power LED is on, if so please proceed with step # 3, if not, continue with the steps below;

1. Check the in line fuse (s) on the battery's positive cable, replace if needed.
2. Assure that the Ground is properly attached to the vehicle's chassis on a clean metal point, tighten or grind the connection point once again.
3. Our amplifiers have a high voltage protection. Make sure that the operating voltage is between 8.5V~16V and voltages above this range will cause the amplifier to go into protect.

Protect LED is ON

The Protect LED will come on due to the possible circumstances;

1. The impedance connected is under the specified load.
2. Thermal (Overheat), allow for a more suitable mounting as recommended in the install section. Thermal may also appear if the impedance is under the specified or the voltage is inadequate.
3. Short circuitry, voltage and DC offset.
Short circuitry, go through all cables including speaker wires, GND, battery's positive cable. Voltage, please check step # 3, for DC offset, make sure that a voltage of no more than 4V is available. Remove the RCA from the input and check whether the amplifier comes out of protect. If so, check if the output from the Head unit has a DC of 4V, replace / repair if needed.

Audio output (No sound)

1. Assure that RCA connections from the Head unit and the amplifier is properly connected. Check the entire cable for damages or its like. Test the RCA inputs for DC volts with the source unit on, replace / repair if needed.
2. Check the routing of the cables, fuses and verify that all connections are connected accordingly.
3. Check whether the speakers are functional.

Turn on Thump

Disconnect the signal input to the amplifier, then turn it on and off.

1. If the noise is cancelled, then connect a delay turn on module on the REM wire running from the source unit to the amplifier.
2. Use another 12V source for REM lead to the amplifier. If the noise is cancelled, use a relay to isolate the amplifier from the turn on thump.

Poor Bass Response

1. Check that the polarity of the speaker cables are correct. Speakers connected in anti-phase will cancel each other, thus the bass response will be absent.

Engine Noise

1. Ensure that all signal transferring wires (RCA, speaker cables etc) are kept separate from the power and the ground wires.
2. Bypass all electrical components between the Head unit and the amplifier.
Connect the Head unit directly to the amplifier's input. If the noise is eliminated, the unit bypassed is the one causing the noise.
3. Remove the existing ground wires for all electrical components installed. Ensure that the point of ground is 100% metal which has been grinded free of rust, paint etc.
4. Replace the ground cable from the OEM battery / alternator and ensure it is grounded accordingly.
5. Test the battery and alternator load (can be carried out by a professional).
Ensure that the vehicle's electrical system is in a good condition, this includes distributor, spark plugs / wires, voltage regulators etc.



EXCURSION LIMITED WARRANTY POLICY

EXCURSION Intl. offers limited warranty on EXCURSION products under normal use on the following terms:

EXCURSION Amplifiers are to be free of defects in material and workmanship for a period of one year.

This warranty applies only to EXCURSION products sold to consumers by Authorized EXCURSION Dealers in Germany. Products purchased by consumers from an EXCURSION dealer in another country are covered only by that country's Distributor and not by EXCURSION Intl.

This warranty covers only the original purchaser of EXCURSION product. In order to receive service, the purchaser must provide EXCURSION with the receipt stating the consumer name, dealer, product and date of purchase.

Products found to be defective during the warranty period will be repaired or replaced (with a product deemed to be equivalent) at Excursion's discretion and will not be liable for incidental or consequential damages. EXCURSION will not warranty this product under the following situations:

- * **Amplifiers received with apparent rust or corrosion**
- * **Any evidence of liquid damage or exposure to excessive heat**
- * **Attempted repairs or alterations of any nature**
- * **Product that has not been installed according to this owner manual**

Any implied warranties including warranties of fitness for use and merchantability are limited in duration to the period of the express warranty set forth above. No person is authorized to assume for EXCURSION any other liability in connection with the sale of this product.

Please call prior your authorized EXCURSION dealer the product got purchased. In case they are not accessible get in contact with the EXCURSION Customer Service. You must obtain an RA# (Return Authorization Number) to return any product to EXCURSION Intl. The RA number must be prominently marked on the outside of the shipping carton or the delivery will be refused. Please pack your return carefully! We are not responsible for items damaged in shipping. Return the defective product along with a copy of the original dated retail sales receipt, plus 10,- EUR for handling and diagnostic evaluation to:

EXCURSION Intl. - A Division of CHPW
Attn: Returns (RA#)
Neustaedter Str. 20
D-92685 Floss / Germany



...is all you need



EXCURSION - A Division of CHPW

All Rights reserved - Intl. Trademark No: 010 640 597

Friedrich-Ebert-Str. 42 - D-92637 Weiden / Germany

